

DIVER 6

6" MULTISTAGE SUBMERSIBLE PUMPS

DOMESTIC WATER SUPPLY



Multi-stage powerful submersible pumps ideal for rain water systems, operating sprinklers, pumping water from tanks, cisterns, ponds and wells and other applications that require high pressure. Available with 2, 3 and 4 impellers. Suitable to pump clear water.
Anti-corrosive and rust-proof materials.
Motor with thermic overload protection.
Wear resistant shaft.
Anti-debris stainless steel strainer.

Excellent cooling of the motor that enables the pump to operate even when it is partially submersible. Automatic version with start/ stop float switch. Supplied with power cable with plug, non return valve and 4-step fitting.

TECHNICAL DATA

MODEL	CODE	ELECTRICAL DATA			HYDRAULIC DATA								CABLE LENGTH mt.	
		VOLTAGE 50 Hz	P2 NOMINAL		Q m ³ /h l/min	0	0,9	1,8	2,7	3,6	4,5	5,1		5,4
			kW	HP		H (m)	0	15	30	45	60	75	85	90
DIVER 6 - 600 M-A	60122630	1 x 230V	0,55	0,75	H (m)	24	22	19,5	16,2	12,5	7,5	3,7	1,5	15
DIVER 6 - 700 M-A	60122631	1 x 230V	0,65	0,88		36	32,6	28,5	23,6	17	9,5	4,6	1,8	15
DIVER 6 - 850 M-A	60122632	1 x 230V	0,75	1		46	41	35,5	29,2	21,8	13,5	7,8	3,5	15

DIVER 6

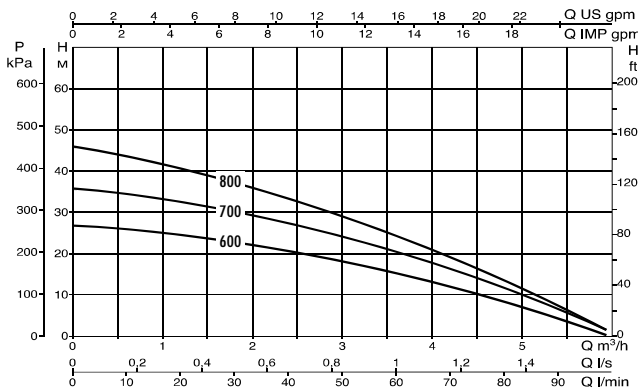

DIMENSIONS AND WEIGHTS

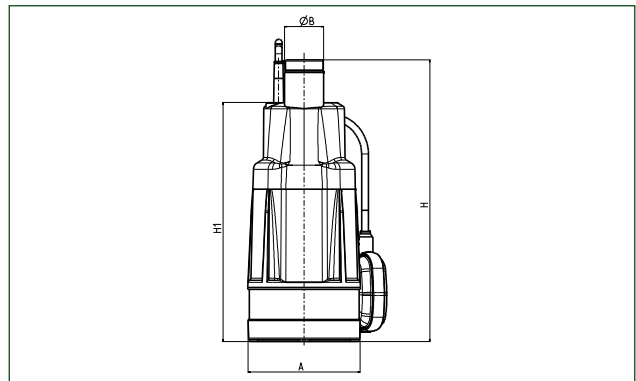

MODEL	A	Ø B	H	H1	Ø	PACKAGING DIMENSION m ³	GROSS WEIGHT Kg
DIVER 6 600 M-A	150	52	350	293	1"	0,008	7,5
DIVER 6 700 M-A	150	52	375	318	1"	0,008	8,7
DIVER 6 800 M-A	150	52	400	343	1"	0,009	9