

# FEKA BVP SEWAGE PUMPS



## SUBMERSIBLE PUMPS FOR DRAINAGE WATER

**Powerful** submersible pumps for **drainage and emptying duty**. Designed for pumping foul water containing solid particles of no more than 38 mm in diameter.  
Anti-corrosion and anti-oxidation materials.  
Motor with thermal protection against overheating.  
Wear-resistant motor shaft and impeller.

Excellent motor cooling to allow pump to run even when only partially submerged.  
Automatic version equipped with float switch for automatic starting and stopping of the pump, and Manual version. Equipped with power cable with plug, and 3-level union, without check valve.

PANELS - ACCESSORIES

PAG. 442

## TECHNICAL DATA

MODEL	CODE	ELECTRICAL DATA					HYDRAULIC DATA														
		VOLTAGE 50 HZ	P1 MAX kW	P2 NOMINAL		In	Q=m³/h	0	1	2	3	4,5	5	6	7	7,5	9	10	12	15	18
FEKA BVP 700 M-A	60122690	1X230 V~	1,0	0,70	0,95	4,6	Q=l/min	0	16,6	33,3	50	75	83,3	100	116,6	125	150	166,6	200	250	300
FEKA BVP 750 M-A	60122691	1X230 V~	1,1	0,75	1	5,6	H (m)	10,5	10	9,9	9,5	8,9	8,8	8,1	7,8	7,5	7	6,1	5,1	4	1,5
								12	11,7	11,1	11	10,4	10,1	9,8	9,1	9	8,8	8	7	6	3,6

## FEKA BVP

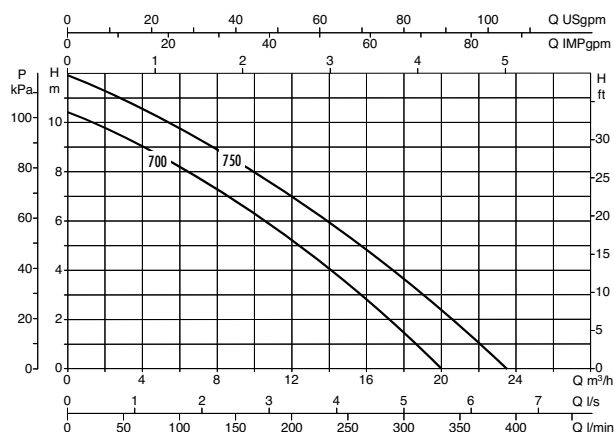

## DIMENSIONS AND WEIGHTS

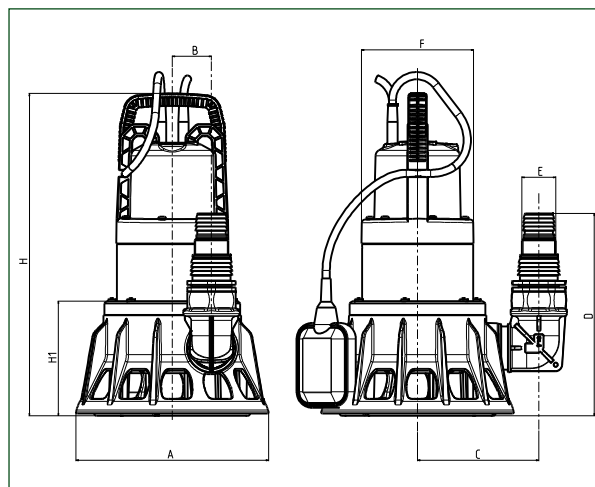

MODEL	A	B	C	D	E	F	H	H1	DNM GAS	CABLE	WEIGHT KG	Q.TY X PALLETS
FEKA BVP 700 M-A	240	49	150	250	M40	140	400	142	1 1/2"	10 mt.	8	27
FEKA BVP 750 M-A	240	49	150	250	M40	140	400	142	1 1/2"	10 mt.	8	27