

STAX
STAXX MATERIAL HANDLING EQUIPMENT CO., LTD

ELECTRIC STACKER

FES10/30

Make
Your Job
Easier

www.cnmhe.com

LOAD CHART

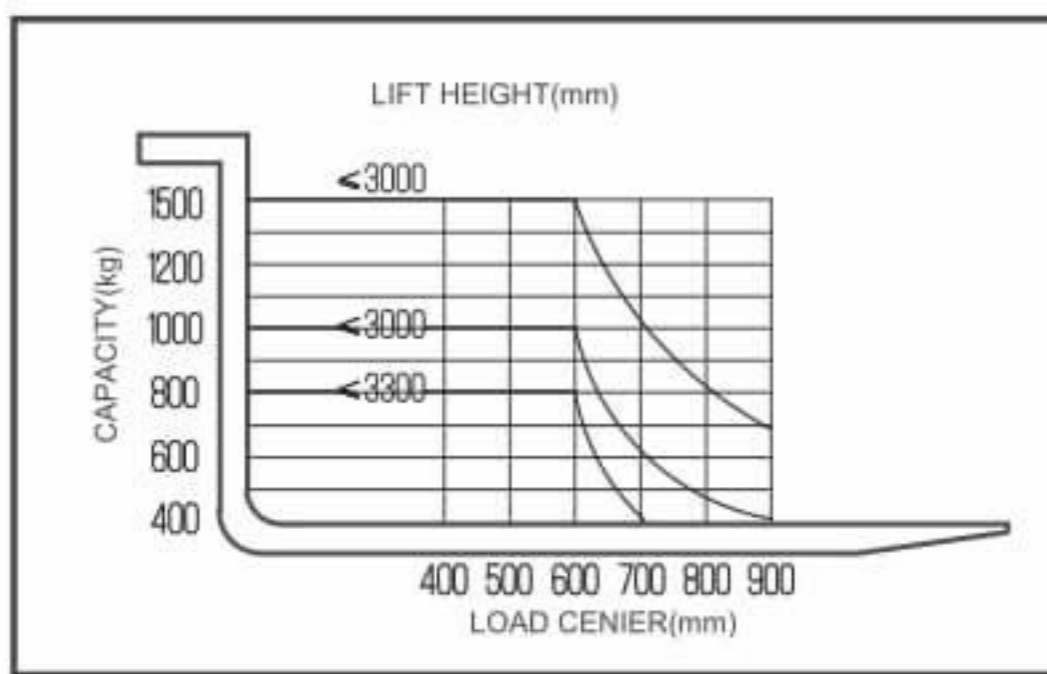

FES10/30

STAXX
STAXX MATERIAL HANDLING EQUIPMENT CO., LTD

ELECTRIC STACKER

MODEL		PWS10S	PWS15S
CHARACTERISTICS			
1.1	Drive unit	Electric	Electric
1.2	Operator type	Walkie	Walkie
1.3	Capacity	kg	1500
1.4	Load center distance	mm	600
1.5	Wheel base	mm	1245
WEIGHT			
2.1	Service weight(with battery)	kg	450/500/520/550
2.2	Service weight(without battery)	kg	500/550/570/600
WHEEL			
3.1	Tyre type driving wheels/loading wheels	PU	PU
3.2	Size of loading wheels	mm	φ78
3.3	Size of driving wheel	mm	φ210
3.3	Size of balance wheel	mm	φ180
3.4	Wheel quantity	pcs	4
SPECIFICATIONS			
4.1	Lift height	mm	1600/2500/3000/3300
4.2	Mast lower height	mm	2065/1785/2035/2185
4.3	Mast extend height	mm	2065/3000/3500/3800
4.5	Overall length	mm	1770
4.7	Overall width	mm	800
4.8	Fork dimensions	mm	54x160x1125
4.9	Width across forks	mm	560/680
4.1	Lowered height of fork	mm	90
4.11	Clearance	mm	30
4.12	Aisle width for pallets (1000 x 1200mm)	mm	2256
4.13	Aisle width for pallets (800 x 1200mm)	mm	2184
4.14	Min turning radius	mm	1390
PERFORMANCE			
5.1	Travelling speed, laden/unladen	km/h	2.5/3.0
5.2	Lifting speed, laden/unladen	mm/s	100/112
5.3	Lowering speed, laden/unladen	mm/s	92/85
5.4	Max. gradeability, laden/unladen	%	5/7
5.5	Service brake type		Electronic
ELECTRIC ENGINE			
6.1	Driving motor	kw	0.65
6.2	Lifting motor	kw	2.2
6.3	Battery voltage/capacity	V/Ah	12/75X2
6.4	Battery size	mm	(260x172x214)x2
6.5	Controller		1212P-2501 (CURTIS)

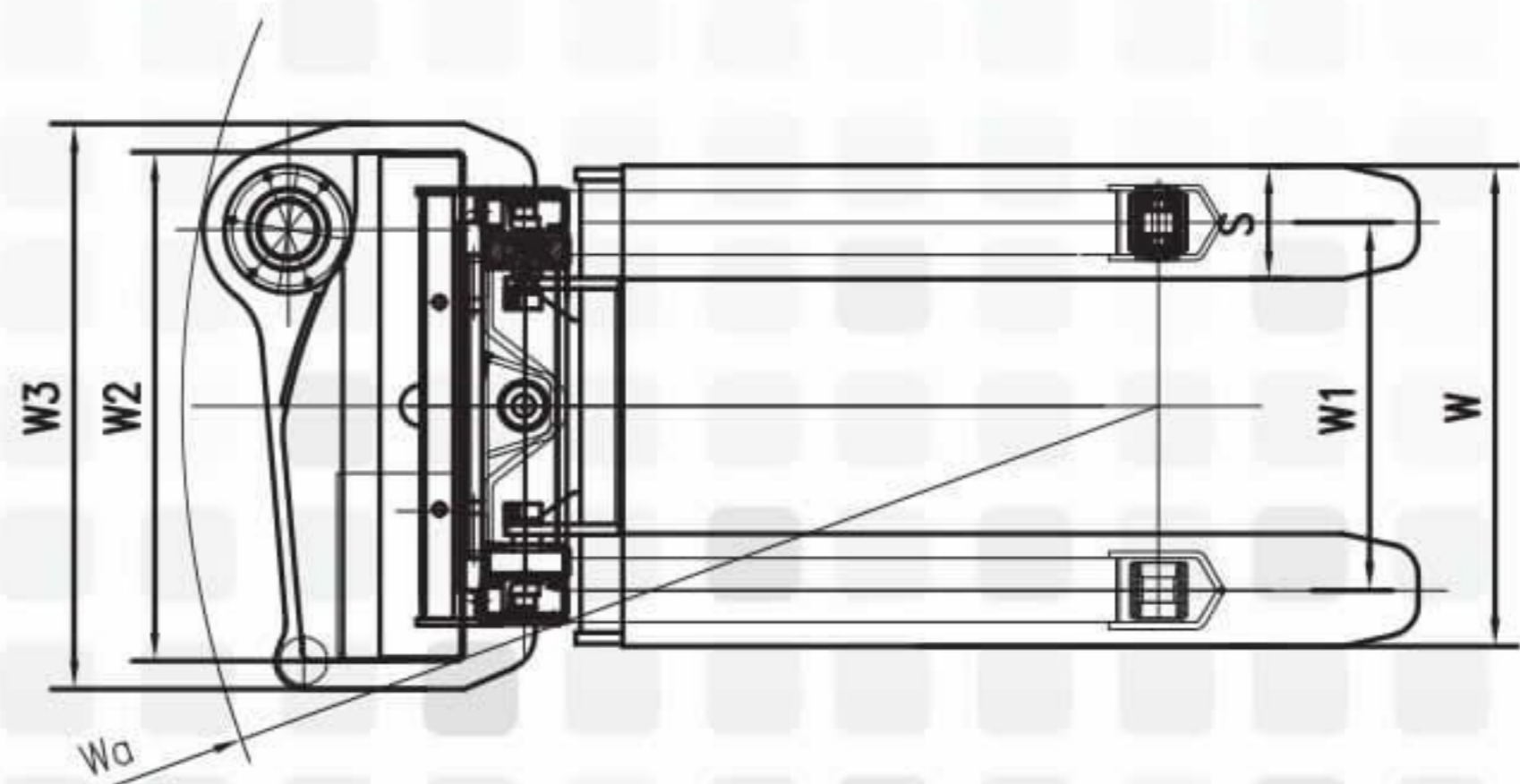
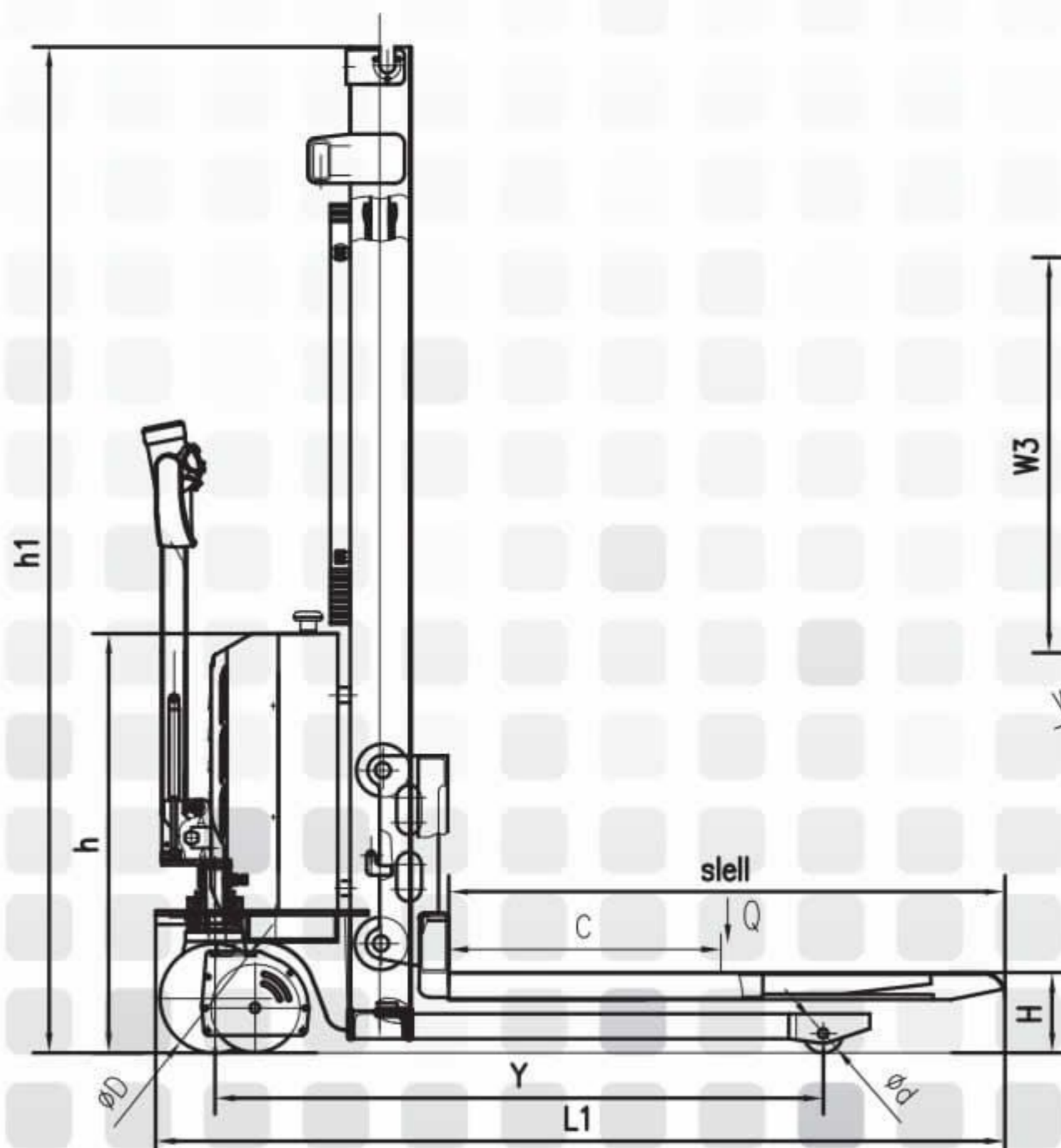

www.cnmhe.com